

Battery less Multi-turn Absolute Encoder

Hollow shaft type **Model : 38HA-MS**

■ Features

- 39-bits resolution: 16-bits energy harvesting multi-turn & 23-bits optical single-turn
- Built-in communication protocol (option): BiSS C mode, SSI mode & RS-485 half-duplex
- Overall encoder outer diameter $\varnothing 38$ mm and maximum height of 40 mm
- Supporting $\frac{1}{4}$ inch, 6mm and 8mm diameter of the blind hollow shaft



■ Model

38HA-MS - - **200-00E**

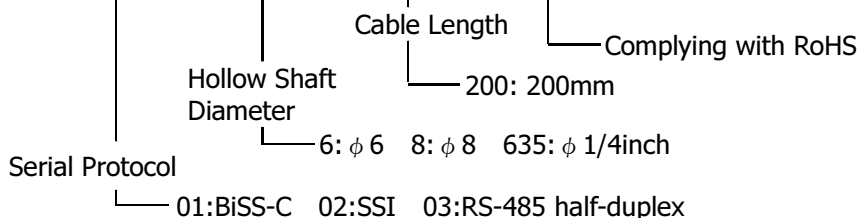

■ Specification

1. Basic specification

General		
Outside diameter	38mm	At housing
Height	40mm	
Bearing	With Bearing	
Shaft	Hollow shaft	
Shaft Diameter	1/4 inch, $\phi 6$, $\phi 8$	
Measuring Methods	Optical transparent / Absolute	
Electrical		
Single-turn Resolution	23bits (8,388,607 counts)	
Multi-turn Resolution	16bits (65,535 counts)	
DC Supply Voltage	5.0V $\pm 10\%$	
Main Supply Current	Typical 115mA	Without load, Ta=+25°C
Electrically Permissible Speed	$\leq 6,000\text{min}^{-1}$	
Output Communication	BiSS-C, SSI, RS-485 half duplex	
Mechanical		
System Accuracy	Typical ± 80 Arc-sec	With electrical correction, Ta=+25°C
Mechanical Permissible Speed	$\leq 6,000\text{min}^{-1}$	
Shaft Radial Play	$\leq \pm 0.05$ mm	

Shaft Axial Play	$\leq \pm 0.1 \text{ mm}$	
Starting torque	$\leq 9.8 \times 10^{-3} \text{ N.m}$	Ta = +25°C
Environmental		
Operating Temperature Range	-20°C~105 °C	
Storage Temperature Range	-20°C ~105°C	
Vibration	$\leq 98 \text{ m/s}^2$ 10 to 2000Hz	Per IEC 60068-2-6
Shock	$\leq 1960 \text{ m/s}^2$ 6ms; Half Sine	Per IEC 60068-2-27
Protection	IP50	
Relative Air Humidity (Non-Condensing)	Typical RH 90 %	Ta=+40°C
Others		
Counting Direction	Increase with Counter Clockwise (CCW) shaft rotation, view from coupling end (Figure 1)	
Internal Memory	EEPROM	
Usable Memory Area	5kbit	
Initialization Time	500 ms	
Output Connection	Refer to cable connection information	Approximate 200mm (AWG28)

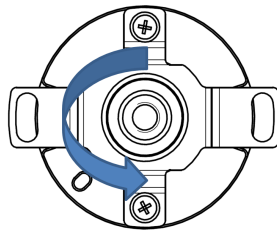

Figure 1

Note: 1. Exposure to absolute maximum rating conditions for extended periods may affect reliability.

Interface Diagram

The following are examples of the circuit diagram of full-duplex and half-duplex transceiver.

Full-duplex transceiver (BiSS C mode / SSI mode protocol):

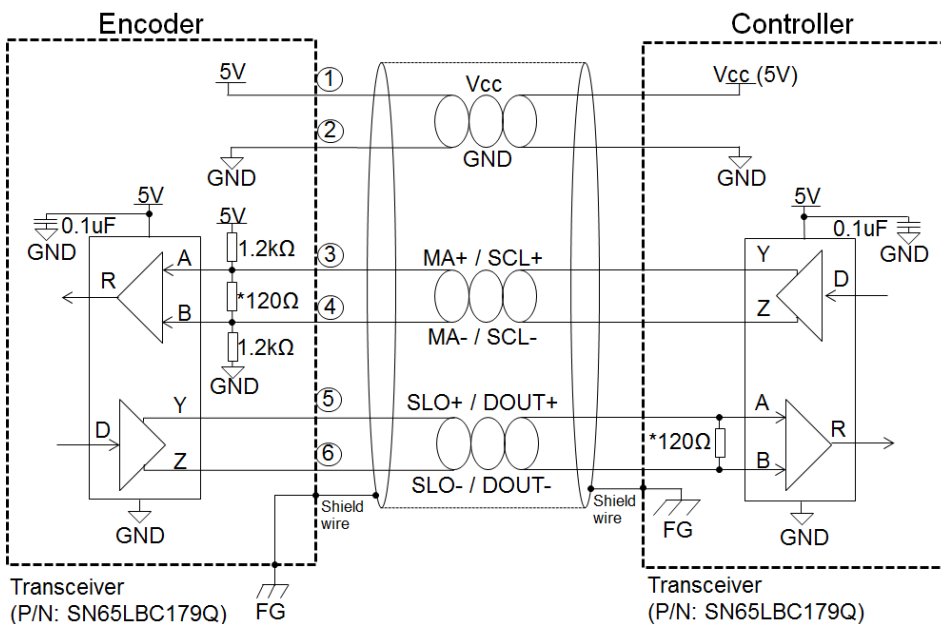

Figure 2: Circuit diagram of full-duplex transceiver

Half-duplex transceiver (RS-485 half-duplex protocol):

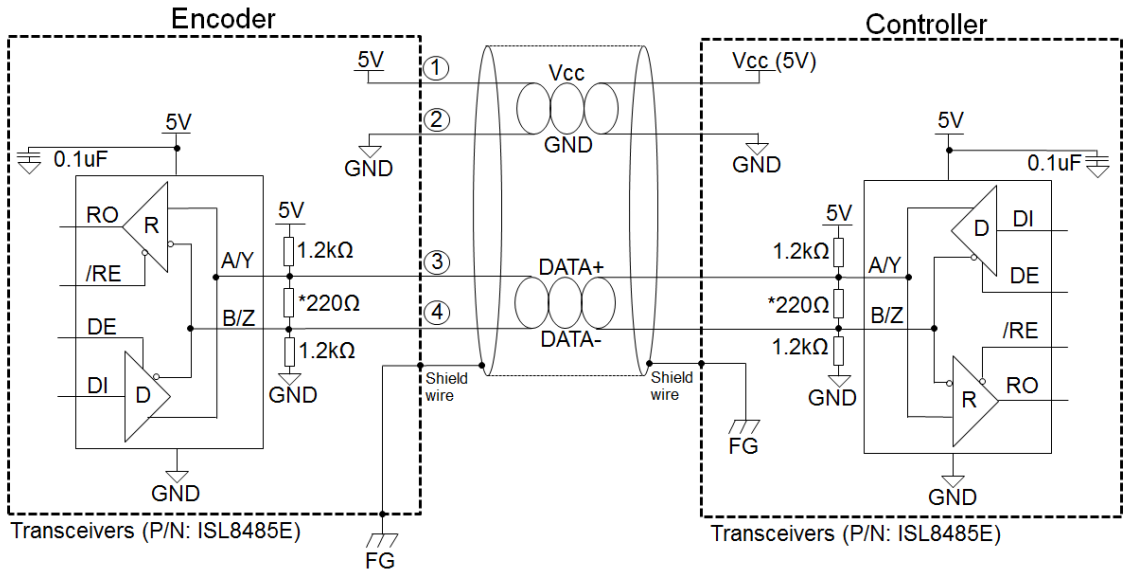

Figure 3: Circuit diagram of half-duplex transceiver

Note:

- 1) Termination resistor, *120ohm and *220ohm are recommended but may depends on the characteristic impedance of cable used.
- 2) Recommended to connect encoder chassis and cable shield to frame ground (FG) in application for enhanced noise immunity in harst operating condition.

■ Cable Connection Information

No	Cable Color	BiSS C mode protocol (output: 7 core cable)	SSI mode protocol (output: 7 core cable)	RS-485 half-duplex protocol (output: 5 core cable)
1	RED	VCC, Positive Supply	VCC, Positive Supply	VCC, Positive Supply
2	BLACK	GND, Ground	GND, Ground	GND, Ground
3	BROWN	MA+	SCL+	DATA+
4	WHITE	MA-	SCL-	DATA-
5	ORANGE	SLO+	DOUT+	N/A
6	BLUE	SLO-	DOUT-	N/A
7	Cable Shield Strand	Cable Shield, Connect to Chassis	Cable Shield, Connect to Chassis	Cable Shield, Connect to Chassis

Note: Cable provided is 200mm +/- 10mm (included pigtail length) with AWG28.

■ Mechanical Drawing

Package Dimension

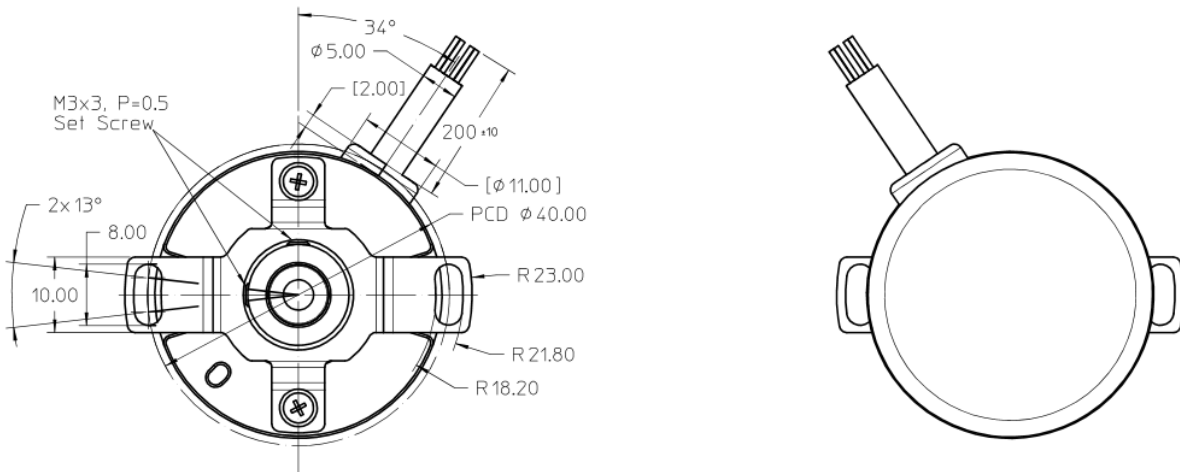

Recommended Shaft and Mounting Requirement

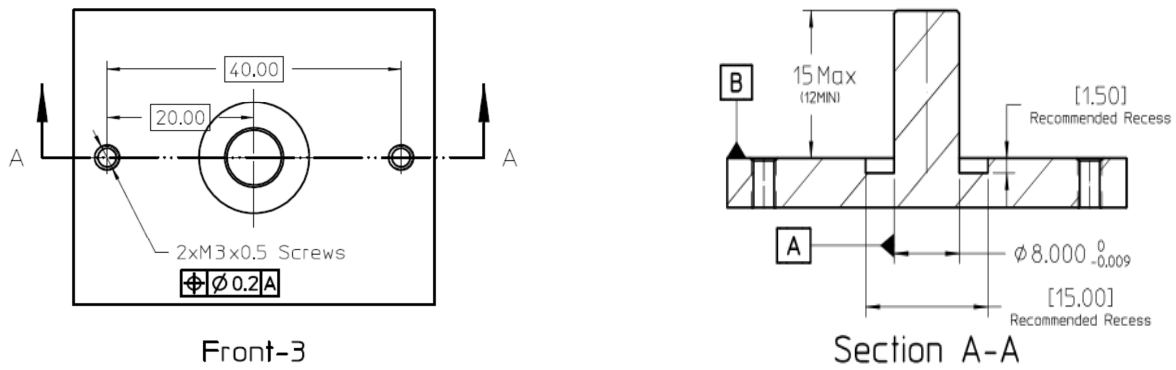

Note:

1. Dimensions are in millimeters
2. 3rd Angle Projection
3. Unless otherwise specified, all tolerances are within ± 0.5 mm
4. Recommended to have a recess on motor mounting surface to prevent encoder shaft interference with motor base.

■ Applications

- Robotics
- Factory automation
- Linear positioning system
- CNC machine tool
- Medical and lab equipment

NOTE

Broadcom encoders are not recommended for use in safety critical applications. E.g. ABS braking systems, power steering, life support systems and critical care medical equipment. Please contact sales representative if more clarification is needed.